

TruCluster Software Products

Hardware Configuration Technical Update for TL893 and TL896 Automated Tape Libraries

December 1999

Product Version: TruCluster Production Server Software
Version 1.6 and TruCluster Available
Server Version 1.6

Operating System and Version: Tru64 UNIX Version 4.0F

This technical update describes how to configure the TL893 and TL896 Automated Tape Libraries (ATL) in a TruCluster Software Products environment. This technical update has been revised to include support for the KZPBA-CB UltraSCSI host bus adapter with the TL893 or TL896 Automated Tape Libraries.

© 1999 Compaq Computer Corporation

COMPAQ, the Compaq logo, and the Digital logo are registered in the U.S. Patent and Trademark Office. Alpha, AlphaServer, NonStop, TruCluster, and Tru64 are trademarks of Compaq Computer Corporation.

Microsoft and Windows NT are registered trademarks of Microsoft Corporation. Intel, Pentium, and Intel Inside are registered trademarks of Intel Corporation. UNIX is a registered trademark and The Open Group is a trademark of The Open Group in the United States and other countries. Other product names mentioned herein may be the trademarks of their respective companies.

Possession, use, or copying of the software described in this publication is authorized only pursuant to a valid written license from Compaq Computer Corporation or an authorized sublicensor.

Compaq Computer Corporation shall not be liable for technical or editorial errors or omissions contained herein. The information in this document is subject to change without notice.

Contents

About This Technical Update

1 TL893/TL896 Automated Tape Library

1.1	General Overview	1-1
1.2	Required Software and Firmware	1-1
1.3	TL893 and TL896 Automated Tape Libraries Overview	1-2

2 Preparing the TL893 and TL896 Automated Tape Libraries for Shared SCSI Bus Usage

2.1	Communications with the Host Computer	2-1
2.2	MUC Switch Functions	2-2
2.3	Setting the MUC SCSI ID	2-2
2.4	Tape Drive SCSI IDs	2-3
2.5	TL893 and TL896 Automated Tape Library Internal Cabling	2-3
2.6	Connecting the TL893 and TL896 Automated Tape Libraries to the Shared SCSI Bus	2-6

Figures

2-1	TL893 Three-Bus Configuration	2-4
2-2	TL896 Six-Bus Configuration	2-6
2-3	Shared SCSI Buses with TL896 in Three-Bus Mode	2-8

Tables

2-1	MUC Switch Functions	2-2
2-2	MUC SCSI ID Selection	2-2
2-3	TL893 Default SCSI IDs	2-3
2-4	TL896 Default SCSI IDs	2-3
2-5	Hardware Components Used in Configuration Shown in Figure 2-3	2-9

About This Technical Update

This technical update provides important information about using the TL893 or TL896 Automated Tape Library (ATL) with the TruCluster™ software products.

Audience

If you plan to configure a TL893 or TL896 ATL in a TruCluster hardware configuration, read this addendum to the TruCluster Software Products *Hardware Configuration* manual.

Organization

This technical update contains an introductory chapter and a chapter covering the use and configuration of the TL893 and TL896 ATLs in a TruCluster configuration.

TL893/TL896 Automated Tape Library

This technical update to the TruCluster Software Products *Hardware Configuration* manual provides important information about support for the TL893 and TL896 Automated Tape Library (ATL) with the TruCluster Production Server Software Version 1.6 and TruCluster Available Server Software Version 1.6 products.

1.1 General Overview

The TL893 and TL896 Automated Tape Libraries (ATLs) were recently qualified for use with the TruCluster Production Server Software Version 1.6 and TruCluster Available Server Software Version 1.6 products with the KZPBA-CB UltraSCSI host bus adapter.

There is no TruCluster Software Products software release that coincides with the availability of support for the TL893 and TL896 ATLs with the KZPBA-CB. This technical update provides the TL893/TL896 configuration information that would be in Chapter 4 of the TruCluster Software Products *Hardware Configuration* manual.

For more information on the TL893 and TL896 ATLs, see the following manuals:

- *TL82X/TL893/TL896 Automated Tape Library for DLT Cartridges Facilities Planning and Installation Guide* (EK-TL820-PG)
- *TL82X/TL893/TL896 Automated Tape Library for DLT Cartridges Operator's Guide* (EK-TL820-OP)
- *TL82X/TL893/TL896 Automated Tape Library for DLT Cartridges Diagnostic Software User's Manual* (EK-TL820-SM)
- *TL82X Cabinet-to-Cabinet Mounting Instructions* (6207217-01)
- *TL82X/TL89X MUML to MUSL Upgrade Instructions* (6207199-01)
- *TZ89 DLT Series Tape Drive User's Guide* (EK-TZ89N-UG)

1.2 Required Software and Firmware

Support for the TL893 and TL896 Automated Tape Libraries (ATLs) with the TruCluster Production Server Software and TruCluster Available Server

Software Version 1.6 products with Tru64 UNIX Version 4.0F requires the following firmware:

- Version 5A2B robotic controller firmware
- Version V80 TZ89 firmware
- Version 2B multi-unit controller (MUC) firmware

Contact your Compaq Services representative for tape drive, library (robotic), and MUC firmware upgrades.

1.3 TL893 and TL896 Automated Tape Libraries Overview

The TL893 and TL896 Automated Tape Libraries (ATLs) are designed to provide high-capacity storage and robotic access for the Digital Linear Tape (DLT) series of tape drives. They are identical except in the number of tape drives and the maximum capacity for tape cartridges.

Each tape library comes configured with a robotic controller and bar code reader (to obtain quick and accurate tape inventories).

The libraries have either three or six TZ89N-AV drives. The TL896, because it has a greater number of drives, has a lower capacity for tape cartridge storage.

Each tape library utilizes bulk loading of bin packs, with each bin pack containing a maximum of 11 cartridges. Bin packs are arranged on an eight-sided carousel that provides either two or three bin packs per face. A library with three drives has a carousel three bin packs high. A library with six drives has a carousel that is only two bin packs high. This provides for a total capacity of 24 bin packs (264 cartridges) for the TL893, and 16 bin packs (176 cartridges) for the TL896.

The tape library specifications are as follows:

- TL893 — The TL893 ATL is a high-capacity, 264-cartridge tape library providing up to 18.4 TB of storage. The TL893 uses three fast-wide, differential TZ89N-AV DLT tape drives. It has a maximum transfer rate of almost 10 MB per second (compressed) for each drive, or a total of about 30 MB per second.

The TL893 comes configured for three SCSI-2 buses (a three-bus configuration). The SCSI bus connector is high-density 68-pin, differential.

- TL896 — The TL896 ATL is a high-capacity, 176-cartridge tape library providing up to 12.3 TB of storage. The TL896 uses six fast-wide, differential TZ89N-AV DLT tape drives. It also has a maximum transfer rate of almost 10 MB per second per drive (compressed), or a total of about 60 MB per second.

The TL896 comes configured for six SCSI-2 buses (a six-bus configuration). The SCSI bus connector is also high-density 68-pin, differential.

Both the TL893 and TL896 can be extended by adding additional cabinets (DS-TL893-AC for the TL893 or DS-TL896-AC for the TL896). See *TL82X Cabinet-to-Cabinet Mounting Instructions* for information on adding additional cabinets. Up to five cabinets are supported with the TruCluster products.

For the TruCluster Software products, the tape cartridges in all the cabinets are combined into one logical unit, with consecutive numbering from the first cabinet to the last cabinet, by an upgrade from the multi-unit, multi-LUN (MUML) configuration to a multi-unit, single-LUN (MUSL) configuration. See the *TL82X/TL89X MUML to MUSL Upgrade Instructions* manual for information on the firmware upgrade.

2

Preparing the TL893 and TL896 Automated Tape Libraries for Shared SCSI Bus Usage

The topics in this chapter provide information on preparing the TL893 and TL896 Automated Tape Libraries (ATLs) for use on a shared SCSI bus with the TruCluster Production Server Software Version 1.6 and TruCluster Available Server Software Version 1.6 products.

Note

We recommend placing no more than two TZ89 tape drives on a SCSI bus, and also recommend that no shared storage be placed on the same SCSI bus with the tape drive.

The TL893 and TL896 ATLs for Digital Linear Tape (DLT) cartridges are identical except for the number of tape drives installed and the total cartridge capacity.

These tape libraries each have a multi-unit controller (MUC) that serves two functions:

- It is a SCSI adapter that allows the SCSI interface to control communications between the host and the tape library.
- It permits the host to control up to five attached library units in a multi-unit configuration. Multi-unit configurations are not discussed in this update. For more information on multi-unit configurations, see the *TL82X/TL893/TL896 Automated Tape Library for DLT Cartridges Facilities Planning and Installation Guide*.

The following sections describe how to prepare these tape libraries in more detail.

2.1 Communications with the Host Computer

Two types of communications are possible between the tape library and the host computer: SCSI and EIA/TIA-574 serial (RS-232 for 9-pin connectors). Either method, when used with the multi-unit controller (MUC), allows a single host computer to control up to five units.

The TruCluster Available Server Software and TruCluster Production Server Software products support only SCSI communications between the host computer and the MUC. With SCSI communications, both control signals and data flow between the host computer and tape library use the same SCSI cable. The SCSI cable is part of the shared SCSI bus.

An RS-232 loopback cable must be connected between the Unit 0 and Input 9-pin connectors on the rear connector panel. The loopback cable connects the MUC to the robotic controller electronics.

Switch 7 on the MUC switch pack must be down to select the SCSI bus.

2.2 MUC Switch Functions

Switch pack 1 on the rear of the multi-unit controller (MUC) is located below the MUC SCSI connectors. The switches provide the functions shown in Table 2–1.

Table 2–1: MUC Switch Functions

Switch	Function
1, 2, and 3	MUC SCSI ID if Switch 7 is down ^a
4 and 5	Must be down, reserved for testing
6	Default is up, disable bus reset on power up
7	Host selection: Down for SCSI, up for serial ^a
8	Must be down, reserved for testing

^aFor TruCluster Available Server Software and TruCluster Production Server Software configurations, switch 7 is down, allowing switches 1, 2, and 3 to select the MUC SCSI ID.

2.3 Setting the MUC SCSI ID

The multi-unit controller (MUC) SCSI ID is set with switch 1, 2, and 3, as shown in Table 2–2. Note that switch 7 must be down to select the SCSI bus and enable switches 1, 2, and 3 to select the MUC SCSI ID.

Table 2–2: MUC SCSI ID Selection

MUC SCSI ID	SW1	SW2	SW3
0	Down	Down	Down
1	Up	Down	Down
2	Down	Up	Down ^a
3	Up	Up	Down
4	Down	Down	Up

Table 2–2: MUC SCSI ID Selection (cont.)

MUC SCSI ID	SW1	SW2	SW3
5	Up	Down	Up
6	Down	Up	Up
7	Up	Up	Up

^aThis is the default MUC SCSI ID.

2.4 Tape Drive SCSI IDs

Each tape library arrives with default SCSI ID selections. The TL893 is shown in Table 2–3. The TL896 is shown in Table 2–4.

If you must modify the tape drive SCSI IDs, use the push-button up-down counters on the rear of the drive to change the SCSI ID.

Table 2–3: TL893 Default SCSI IDs

SCSI Port	Device	Default SCSI ID
C	MUC	2
	Drive 2 (top)	5
B	Drive 1 (middle)	4
A	Drive 0 (bottom)	3

Table 2–4: TL896 Default SCSI IDs

SCSI Port	Device	Default SCSI ID
D	MUC	2
	Drive 5 (top)	5
E	Drive 4	4
F	Drive 3	3
A	Drive 2	5
B	Drive 1	4
C	Drive 0 (bottom)	3

2.5 TL893 and TL896 Automated Tape Library Internal Cabling

The default internal cabling configurations for the TL893 and TL896 Automated Tape Libraries (ATLs) is as follows:

- The SCSI input for the TL893 is high-density, 68-pin differential. The default internal cabling configuration for the TL893 is a three-bus mode shown in Figure 2–1 as follows:
 - The top shelf tape drive (SCSI ID 5) and MUC (SCSI ID 2) are on SCSI Port C and are terminated on the MUC. To allow the use of the same MUC and terminator used with the TL822 and TL826, a 68-pin to 50-pin adapter is used on the MUC to connect the SCSI cable from the tape drive to the MUC. In Figure 2–1 it is shown as part number 0425031, the SCSI Diff Feed Through. This SCSI bus is terminated on the MUC with terminator part number 0415498, a 50-pin Micro-D terminator.
 - The middle shelf tape drive (SCSI ID 4) is on SCSI Port B and is terminated on the drive with a 68-pin Micro-D terminator, part number 0415619.
 - The bottom shelf tape drive (SCSI ID 3) is on SCSI Port A and is also terminated on the drive with a 68-pin Micro-D terminator, part number 0415619.

Figure 2–1: TL893 Three-Bus Configuration

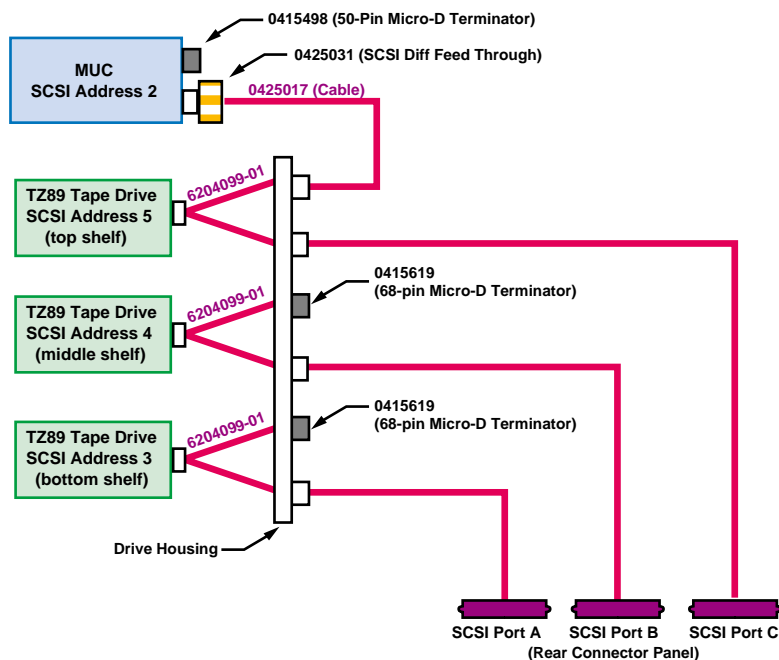

ZK-1326U-AI

- The SCSI input for the TL896 is also high-density, 68-pin differential. The default internal cabling configuration for the TL896 is a six-bus configuration shown in Figure 2–2 as follows:
 - The upper bay top shelf tape drive (tape drive 5, SCSI ID 5) and MUC (SCSI ID 2) are on SCSI Port D. To allow the use of the same MUC and terminator used with the TL822 and TL826, a 68-pin to 50-pin adapter is used on the MUC to connect the SCSI cable from the tape drive to the MUC. In Figure 2–2 it is shown as part number 0425031, SCSI Diff Feed Through. This SCSI bus is terminated on the MUC with terminator part number 0415498, a 50-pin Micro-D terminator.
 - The upper bay middle shelf tape drive (tape drive 4, SCSI ID 4) is on SCSI Port E and is terminated on the tape drive.
 - The upper bay bottom shelf tape drive (tape drive 3, SCSI ID 3) is on SCSI Port F and is terminated on the tape drive.
 - The lower bay top shelf tape drive (tape drive 2, SCSI ID 5) is on SCSI Port A and is terminated on the tape drive.
 - The lower bay middle shelf tape drive (tape drive 1, SCSI ID 4) is on SCSI Port B and is terminated on the tape drive.
 - The lower bay bottom shelf tape drive (tape drive 0, SCSI ID 3) is on SCSI Port C and is terminated on the tape drive.
 - The tape drive terminators are 68-pin differential terminators, part number 0415619.

Figure 2-2: TL896 Six-Bus Configuration

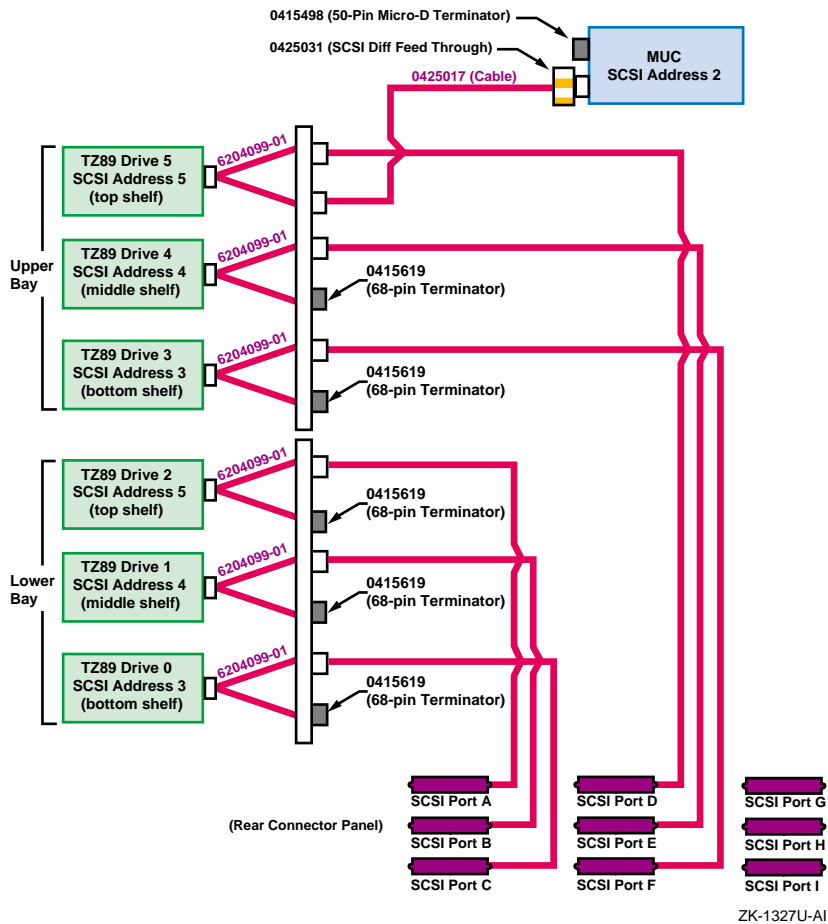

2.6 Connecting the TL893 and TL896 Automated Tape Libraries to the Shared SCSI Bus

The TL893 and TL896 Automated Tape Libraries (ATLs) have up to 3 meters of internal SCSI cabling on each SCSI bus. Because of the internal SCSI cable lengths, it is not possible to use a trilink connector or Y cable to terminate the SCSI bus external to the library as is done with other devices on the shared SCSI bus. Each SCSI bus must be terminated internal to the tape library at the tape drive itself with the installed SCSI terminators. Therefore, TL893 and TL896 tape libraries must be on the end of the shared SCSI bus.

In a TruCluster configuration with TL893 or TL896 tape libraries, the member systems and StorageWorks enclosures or DEC RAID subsystems

may be isolated from the shared SCSI bus because they use tralink connectors or Y cables. However, if there is disk storage and an ATL on the same shared SCSI bus, the ASE must be shut down to remove a tape library from the shared bus.

You can reconfigure the tape drives and robotics controller to generate other bus configurations by using the jumper cable (ATL part number 0425017) supplied in the accessories kit shipped with each TL893 or TL896 unit.

Remove the terminator from one drive and remove the internal SCSI cable from the other drive to be daisy chained. Use the jumper cable to connect the two drives and place them on the same SCSI bus.

Note

We recommend placing no more than two TZ89 tape drives on a SCSI bus, and also recommend that no shared storage be placed on the same SCSI bus with the tape drive.

Figure 2-3 shows a sample Production Server configuration using a TL896 tape library in a three-bus configuration. In this configuration, tape drive 4 (Port E) has been jumpered to tape drive 5, tape drive 2 (Port A) has been jumpered to tape drive 3, and tape drive 1 (Port B) has been jumpered to tape drive 0.

To add a TL893 or TL896 tape library to a shared SCSI bus, select the member system that will be the next to the last device on the shared SCSI bus (the tape library always has to be the last device on the shared SCSI bus). Connect a BN21K, BN21L, or BN31G cable between the Y cable on the SCSI bus controller on that member system and the appropriate tape library port. In Figure 2-3, one shared SCSI bus is connected to port B (tape drives 0 and 1), one shared SCSI bus is connected to port A (tape drives 2 and 3), and a third shared SCSI bus is connected to port E (tape drives 4 and 5 and the MUC).

Figure 2-3: Shared SCSI Buses with TL896 in Three-Bus Mode

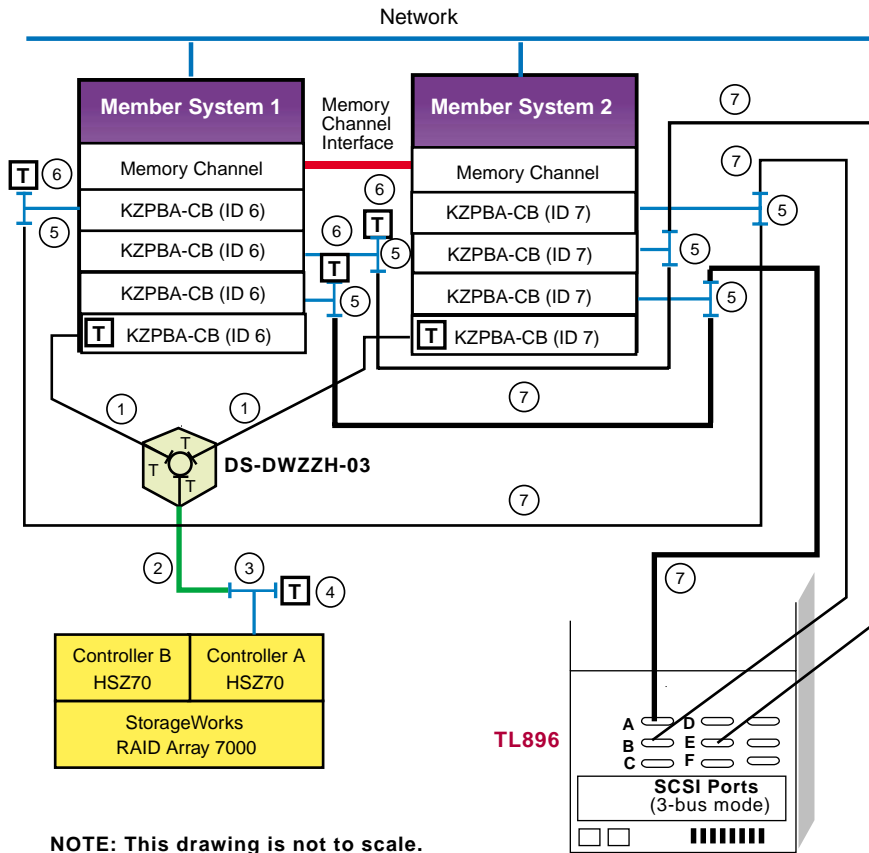

NOTE: This drawing is not to scale.

ZK-1626U-AI

Table 2-5 shows the components used to create the configuration shown in Figure 2-3.

Table 2–5: Hardware Components Used in Configuration Shown in Figure 2–3

Callout Number	Description
1	BN38C or BN38D cable ^a
2	BN37A cable ^b
3	H8861-AA VHDCI trilink connector
4	H8863-AA VHDCI terminator
5	BN21W-0B Y cable
6	HD68 terminator (H879-AA)
7	BN21K, BN21L, or BN31G HD68 cable ^c

^aThe maximum length of the BN38C or BN38D cable on one SCSI bus segment must not exceed 25 meters.

^bThe maximum length of the BN37A cable must not exceed 25 meters.

^cThe maximum combined length of the BN21K, BN21L, or BN31G cables must not exceed 22 meters to allow for up to 3 meters of cabling internal to the tape library.