

TruCluster Software Products

Hardware Configuration Technical Update for TL894 Digital Linear Tape (DLT) Automated Tape Library

December 1999

Product Version: TruCluster Production Server Software
Version 1.6 and TruCluster Available
Server Software Version 1.6

Operating System and Version: Tru64 UNIX Version 4.0F

This technical update describes how to configure the TL894 DLT Automated Tape Library (ATL) in a TruCluster Software Products environment. This technical update has been revised to include support for the KZPBA-CB UltraSCSI host bus adapter with the TL894.

© 1999 Compaq Computer Corporation

COMPAQ, the Compaq logo, and the Digital logo are registered in the U.S. Patent and Trademark Office. Alpha, AlphaServer, NonStop, TruCluster, and Tru64 are trademarks of Compaq Computer Corporation.

Microsoft and Windows NT are registered trademarks of Microsoft Corporation. Intel, Pentium, and Intel Inside are registered trademarks of Intel Corporation. UNIX is a registered trademark and The Open Group is a trademark of The Open Group in the United States and other countries. Other product names mentioned herein may be the trademarks of their respective companies.

Possession, use, or copying of the software described in this publication is authorized only pursuant to a valid written license from Compaq Computer Corporation or an authorized sublicensor.

Compaq Computer Corporation shall not be liable for technical or editorial errors or omissions contained herein. The information in this document is subject to change without notice.

Contents

About This Technical Update

1 TL894 DLT Automated Tape Library

1.1	General Overview	1-1
1.2	TL894 Overview	1-1

2 Preparing the TL894 DLT Automated Tape Library for Cluster Use

2.1	Preparing the TL894 for Shared SCSI Bus Usage	2-1
2.1.1	TL894 Robotic Controller Required Firmware	2-1
2.1.2	Setting TL894 Robotics Controller and Tape Drive SCSI IDs	2-1
2.1.3	TL894 Tape Library Internal Cabling	2-4
2.1.4	Connecting the TL894 Tape Library to the Shared SCSI Bus	2-5

Figures

2-1	TL894 Tape Library Four-Bus Configuration	2-4
2-2	Shared SCSI Buses with TL894 in Two-Bus Mode	2-6

Tables

2-1	TL894 Default SCSI ID Settings	2-2
2-2	Hardware Components Used in Configuration Shown in Figure 2-2	2-7

About This Technical Update

This technical update provides important information about using the TL894 Digital Linear Tape (DLT) automated tape library with the TruCluster™ software products. The order number is actually DS-TL894-BA, but only the TL894 designation is used in this technical update.

Audience

If you plan to use a TL894 DLT automated tape library in a TruCluster hardware configuration, read this addendum to the TruCluster Software Products *Hardware Configuration* manual.

Organization

This technical update contains an introductory chapter and a chapter covering the use and configuration of the TL894 DLT automated tape library in a TruCluster configuration.

TL894 DLT Automated Tape Library

This technical update to the TruCluster Software Products *Hardware Configuration* manual provides important information about support for the TL894 Digital Linear Tape (DLT) automated tape library with the TruCluster Production Server Software Version 1.6 and TruCluster Available Server Software Version 1.6 products.

1.1 General Overview

The TL894 DLT automated tape library was recently qualified for use with the TruCluster Production Server Software Version 1.6 and TruCluster Available Server Software Version 1.6 products with the KZPBA-CB UltraSCSI host bus adapter.

There is no TruCluster Software Products software release that coincides with the availability of support for the TL894 with the KZPBA-CB UltraSCSI host bus adapter. This technical update provides the TL894 configuration information that would appear in Chapter 4 of the TruCluster Software Products *Hardware Configuration* manual.

For more information on the TL894 DLT automated tape library, see the following reference documentation:

- *TL81X/TL894 Automated Tape Library for DLT Cartridges Facilities Planning and Installation Guide* (EK-TL810-IG)
- *TL81X/TL894 Automated Tape Library for DLT Cartridges Diagnostic Software User's Manual* (EK-TL810-UM)

1.2 TL894 Overview

The TL894 is a midrange DLT automated tape library with four fast-wide, differential tape drives. This tape loader uses differential TZ89N-AV tape drives. The SCSI bus connector is 68-pin, high-density differential.

The TL894 has a capacity of 48 DLT cartridges in a fixed-storage array. An operator accessible load port can hold an additional four cartridges for a total of 52 DLT cartridges. This provides a storage capacity of 1.68 to 1.82 TB uncompressed for the TL894 automated tape library.

Preparing the TL894 DLT Automated Tape Library for Cluster Use

The topics in this chapter provide information on preparing the TL894 DLT automated tape library for use on a shared SCSI bus with the TruCluster Production Server Software Version 1.6 and TruCluster Available Server Software Version 1.6 products.

Tape devices are supported only on those shared SCSI buses that use the KZPSA PCI SCSI adapter or the KZPBA-CB UltraSCSI host bus adapter.

Note

To achieve system performance capabilities, we recommend placing no more than two TZ89 drives on a SCSI bus segment. We also recommend that storage be placed on shared SCSI buses that do not have tape drives.

2.1 Preparing the TL894 for Shared SCSI Bus Usage

The TL894 midrange automated Digital Linear Tape library contains a robotics controller and four differential TZ89 tape drives.

The following sections describe how to prepare the TL894 in more detail.

2.1.1 TL894 Robotic Controller Required Firmware

Robotic firmware Version S2.20 is the minimum firmware revision that will support TruCluster Software Products. For information on upgrading the robotic firmware, see the Flash Download section of the *TL81X/TL894 Automated Tape Library for DLT Cartridges Diagnostic Software User's Manual*.

2.1.2 Setting TL894 Robotics Controller and Tape Drive SCSI IDs

The robotics controller, and each tape drive must have the SCSI ID set (unless the default is sufficient). Table 2–1 lists the default SCSI IDs.

Table 2–1: TL894 Default SCSI ID Settings

SCSI Device	SCSI Address
Robotics Controller	0
Tape Drive 0	2
Tape Drive 1	3
Tape Drive 2	4
Tape Drive 3	5

To set the SCSI ID for the TL894 robotics controller, follow these steps:

1. Press and release the Control Panel STANDBY button and verify that the SDA (Status Display Area) shows System Off-line.
2. Press and release SELECT to enter the menu mode.
3. Verify that the following information is displayed in the SDA:
Menu:
Configuration:
4. Press and release SELECT to choose the Configuration menu.
5. Verify that the following information is displayed in the SDA:
Menu: Configuration
Inquiry
6. Press and release the up or down arrow buttons to locate the SCSI Address submenu, and verify that the following information is displayed in the SDA:
Menu: Configuration
SCSI Address ..
7. Press and release the SELECT button to choose the SCSI Address submenu and verify that the following information is displayed in the SDA:
Menu: Configuration
Robotics
8. Press and release the SELECT button to choose the Robotics submenu and verify that the following information is displayed in the SDA:
Menu: SCSI Address
SCSI ID 0
9. Use the up and down arrow buttons to select the desired SCSI ID for the robotics controller.
10. When the desired SCSI ID is displayed on line 2, press and release the SELECT button.

11. Press and release the up or down button to clear the resulting display from the command.
12. Press and release the up or down button and the SELECT button simultaneously, and verify that System On-line or System Off-line is displayed in the SDA.

To set the SCSI ID for each tape drive if the desired SCSI IDs are different from those shown in Table 2-1, follow these steps:

1. Press and release the Control Panel STANDBY button and verify that the SDA (Status Display Area) shows System Off-line.
2. Press and release SELECT to enter the menu mode.
3. Verify that the following information is displayed in the SDA:

```
Menu:  
Configuration:
```

4. Press and release SELECT to choose the Configuration menu.
5. Verify that the following information is displayed in the SDA:

```
Menu: Configuration  
SCSI Address
```

6. Press and release the SELECT button again to choose SCSI Address and verify that the following information is shown in the SDA:

```
Menu: SCSI Add  
Robotics
```

7. Use the down arrow button to bypass the Robotics submenu and verify that the following information is shown in the SDA:

```
Menu: SCSI Add  
Drive 0
```

8. Use the up and down arrow buttons to select the drive number to set or change.
9. When you have the proper drive number displayed on line 2, press and release the SELECT button and verify that the following information is shown in the SDA:

```
Menu: Drive 0  
SCSI ID 0
```

10. Use the up and down arrow buttons to select the desired SCSI ID for the selected drive.
11. When the desired SCSI ID is displayed on line 2, press and release the SELECT button.
12. Repeat steps 8 through 11 to set or change all other tape drive SCSI IDs.

13. Press and release the up or down button to clear the resulting display from the command.
14. Press and release the up or down button and the SELECT button simultaneously and verify that System On-line or System Off-line is displayed in the SDA.

2.1.3 TL894 Tape Library Internal Cabling

The default internal cabling configuration for the TL894 tape library has the robotics controller and top drive (drive 0) on SCSI bus port 1. Drive 1 is on SCSI bus port 2, drive 2 is on SCSI port 3, and drive 3 is on SCSI bus port 4. A terminator (part number 0415619) is connected to each of the drives to provide termination at that end of the SCSI bus.

This configuration, called the four-bus configuration, is shown in Figure 2–1. In this configuration, each of the tape drives, except drive 0 and the robotics controller, requires a SCSI ID on a separate SCSI bus. The robotics controller and drive 0 use two SCSI IDs on their SCSI bus.

Figure 2–1: TL894 Tape Library Four-Bus Configuration

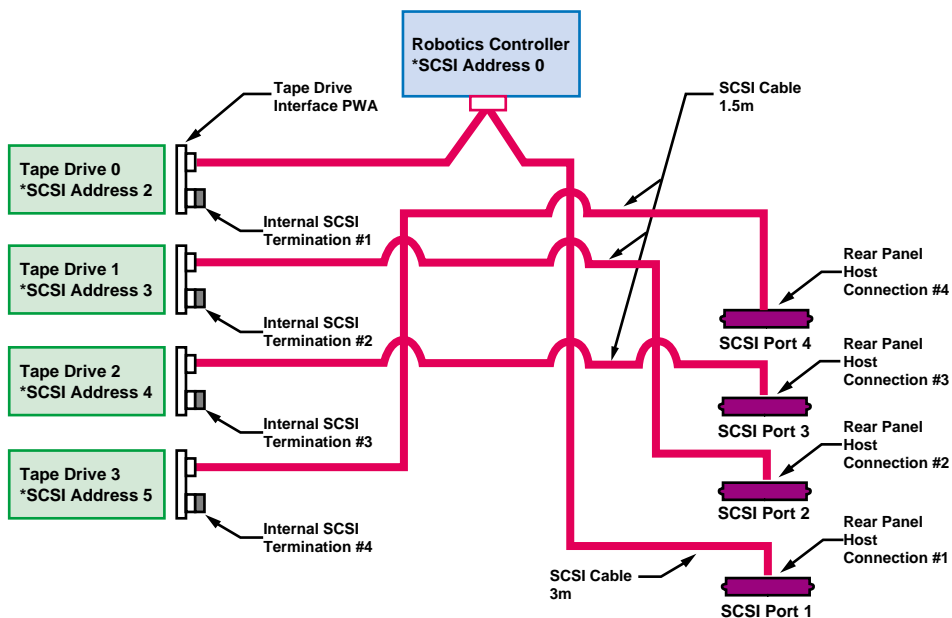

* - Indicates the "default" SCSI ID of the installed devices

ZK-1324U-AI

You can reconfigure the tape drives and robotics controller in a two-bus configuration by using the SCSI jumper cable (part number 6210567) supplied in the accessories kit shipped with each TL894 unit. Remove the

terminator from one drive and remove the internal SCSI cable from the other drive to be daisy chained. Use the SCSI jumper cable to connect the two drives and place them on the same SCSI bus.

Notes

We recommend that you not place more than two TZ89 tape drives on any one SCSI bus in these tape libraries. We also recommend that storage be placed on separate shared SCSI buses.

Therefore, we do not recommended that you reconfigure the TL894 tape library into the one-bus configuration.

Appendix B of the *TL81X/TL894 Automated Tape Library for DLT Cartridges Facilities Planning and Installation Guide* provides figures showing various bus configurations. In these figures, the configuration changes have been made by removing the terminators from both drives, installing the SCSI bus jumper cable on the drive connectors vacated by the terminators, then installing an HD68 SCSI bus terminator on the SCSI bus port connector on the cabinet exterior.

This is not wrong, but by reconfiguring in this manner, the length of the SCSI bus is increased by 1.5 meters, and may cause problems if SCSI bus length is of concern.

In a future revision of the previously mentioned guide, the bus configuration figures will be modified to show all SCSI buses terminated at the tape drives.

2.1.4 Connecting the TL894 Tape Library to the Shared SCSI Bus

The TL894 tape libraries have up to 3 meters of internal SCSI cabling per SCSI bus. Because of the internal SCSI cable lengths, it is not possible to use a trilink connector or Y cable to terminate the SCSI bus external to the library as is done with other devices on the shared SCSI bus. Each SCSI bus must be terminated internal to the tape library, at the tape drive itself with the installed SCSI terminators. Therefore, TruCluster configurations using the TL894 tape library must ensure that the tape library is on the end of the shared SCSI bus.

In a TruCluster configuration with a TL894 tape library, the member systems and StorageWorks enclosures or DEC RAID subsystems may be isolated from the shared SCSI bus because they use trilink connectors or Y cables. However, the ASE must be shut down to remove a tape loader from the shared bus.

Figure 2–2 shows a sample Production Server configuration using a TL894 tape library. In the sample configuration, the tape library has been connected in the two-bus mode by jumpering tape drive 0 to tape drive 1 and tape drive 2 to tape drive 3 (See Section 2.1.3 and Figure 2–1). The two SCSI buses are left at the default SCSI IDs and terminated at drives 1 and 3 with the installed terminators, part number 0415619.

To add a TL894 to a shared SCSI bus, select the member system or storage device that will be the next to last device on the shared SCSI bus. Connect a BN21K, BN21L, or BN31G cable between the Y cable on that device to the appropriate tape library port. In Figure 2–2, one bus is connected to port 1 (robotics controller and tape drives 0 and 1) and the other bus is connected to port 3 (tape drives 2 and 3). Ensure that the terminators are present on the tape drives 1 and 3.

Figure 2–2: Shared SCSI Buses with TL894 in Two-Bus Mode

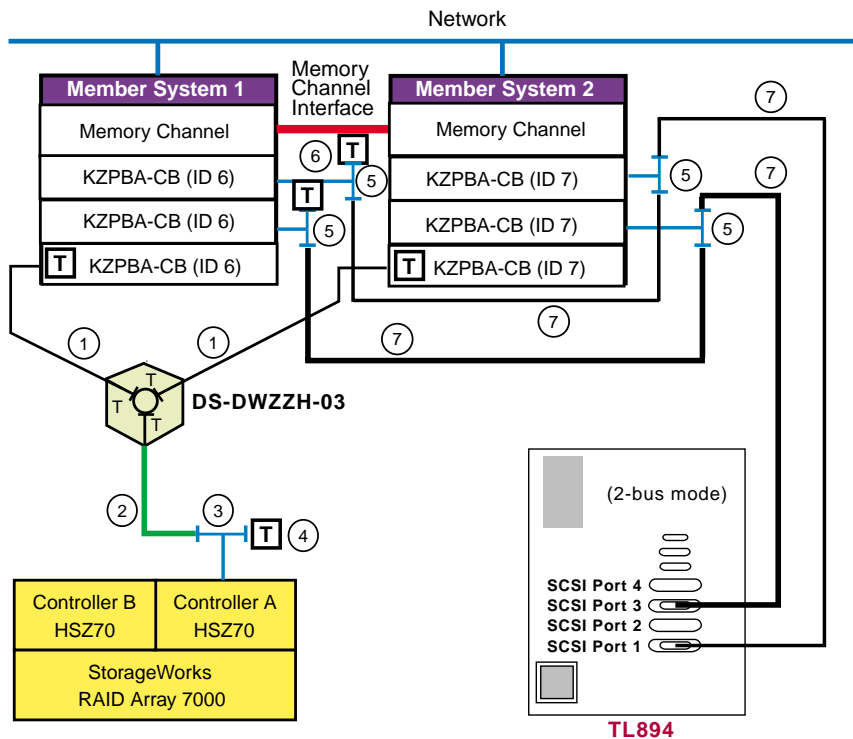

NOTE: This drawing is not to scale.

ZK-1625U-AI

Table 2–2 shows the components used to create the configuration shown in Figure 2–2.

Table 2–2: Hardware Components Used in Configuration Shown in Figure 2–2

Callout Number	Description
1	BN38C or BN38D cable ^a
2	BN37A cable ^b
3	H8861-AA VHDCI trilink connector
4	H8863-AA VHDCI terminator
5	BN21W-0B Y cable
6	HD68 terminator (H879-AA)
7	BN21K, BN21L, or BN31G HD68 cable ^c

^aThe maximum length of the BN38C or BN38D cable on one SCSI bus segment must not exceed 25 meters.

^bThe maximum length of the BN37A cable must not exceed 25 meters.

^cThe maximum combined length of the BN21K, BN21L, or BN31G cables must not exceed 22 meters to allow for up to 3 meters of cabling internal to the tape library.